

Mazak

# UD-400/5X

[ Ultimate Die&Mold ]



High accuracy 5-axis machining center for precision machining



High speed, high accuracy 5-axis machining center

# UD-400/5X



## A sophisticated 5-axis machining center incorporating Mazak's extensive accumulated technologies

- Designed for high speed micro precision machining
- High speed 45000 min<sup>-1</sup> (rpm) spindle
- CNC / software technologies developed for high speed machining of dies and mold
- Double column construction ensures high accuracy over extended periods of operation

### Example workpieces

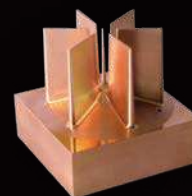



# Machine Design

## High speed 45000 min<sup>-1</sup> (rpm) spindle for higher productivity

Spindle speed	45000 min <sup>-1</sup> (rpm)
Output [40% ED]	13.8 kW (18.5 HP)
Torque [40% ED]	6.9 N·m
Tool shank	HSK-E40

Spindle output / torque diagram

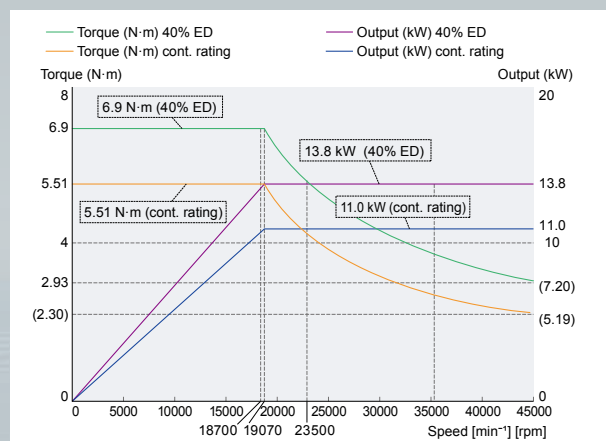

## Integral spindle / motor

Thanks to the integral spindle / motor design, vibration is minimized during high speed operation to ensure exceptional surface finishes and maximum tool life.

## Spindle core cooling

Temperature controlled cooling oil circulates through the spindle core and housing to ensure stable machining accuracy over extended periods of high speed operation.

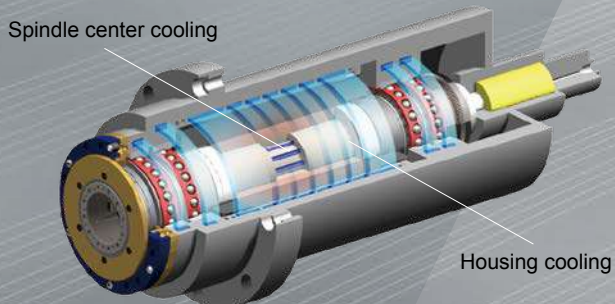

## Symmetrical design

The symmetrical design of the base and column minimizes heat displacement during operation.



### Ball screw core cooling

Temperature controlled cooling oil circulates through the ball screw cores to ensure stable machining accuracy over extended periods of high speed operation.



### High specification linear guides

Higher precision, high rigidity and high damping linear guides provide high straightness and smooth movement to perform high accuracy and high quality machined surfaces.

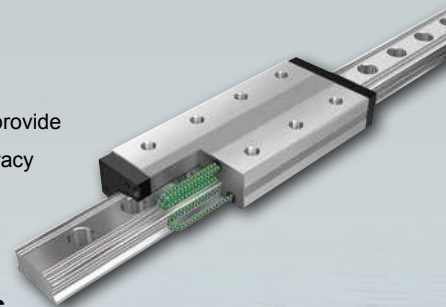

### Direct drive motor utilized by B-, C-axis

Direct drive motors are used for the B- and C-axis. Since this eliminates drive systems with belts and gears - there is no vibration, heat generation and backlash, high accuracy machining is ensured.

### High accuracy scale feedback - standard equipment on linear and rotary axes

High accuracy scale feedback is equipped on the X-, Y-, Z-, B- and C-axis. By detecting absolute position, higher accuracy machining during thermal expansion can be performed.

### Laser tool length measurement



Tool length measurement can be performed on extremely small tools which can not be measured with touch type tool length measurement. Thanks to non-contact measurement by laser beam, tool length and diameter can be measured with the tool rotating to provide stable accuracy.



# MAZATROL CNC System

3 colors status light



19" touch panel

USB port

SD card slot

Operation switches

Dials

Unsurpassed ease of operation with touch screen

MAZATROL **SMOOTHX**

## 5 process home screens

Programming, confirmation, editing and tool data registration



Convenient Parameter Setting and Fine Tuning Function

### SMOOTH MACHINING CONFIGURATION

Machining features including cycle time, finished surface and machining shape can be adjusted by slider switches on the display according to material requirements and machining methods. This is especially effective for complex workpiece contours defined in small program increments. Once the desired results are obtained, the settings can be stored in memory so that they can be easily used again in the future.



Variable Acceleration Control Function

#### ● VARIABLE ACCELERATION CONTROL

Variable acceleration control is a new function which permits the faster acceleration capability of linear axes to be used whenever possible. The slower acceleration of the rotary axes is not used for all program commands, resulting in faster machining cycle times

Seamless Corner Control

#### ● SMOOTH CORNER CONTROL

Improved finished surfaces and reduced cycle times by optimized acceleration / deceleration when machining corners

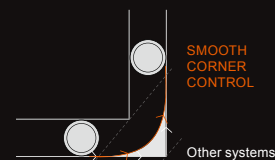

Minimized Vibration

#### ● ACTIVE VIBRATION CONTROL

Minimized vibration function for high speed, high accuracy machining and longer tool life

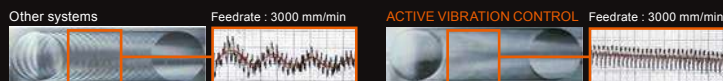

Cycle time reduced by **10 ~ 20%**

(Test results for reference only)



## Standard Machine Specifications

		UD-400/5X
Stroke	X-axis travel (spindle head left / right)	550 mm
	Y-axis travel (table back / forth)	400 mm
	Z-axis travel (spindle head up / down)	350 mm
	B-axis travel (table tilt)	-120° ~ +30°
	C-axis travel (table rotation)	±360°
Table	Table size	□320 mm
	Max. workpiece size	Φ400 mm × 300 mm
	Table load capacity (evenly distributed)	120 kg
Milling spindle	Max. spindle speed	45000 min <sup>-1</sup> (rpm)
Feedrate	Rapid traverse rate (X-, Y-, Z-axis / B-axis / C-axis)	48 m / min / 60 min <sup>-1</sup> (rpm) / 150 min <sup>-1</sup> (rpm)
	Simultaneously controlled axes	5
Automatic tool changer	Tool shank configuration	HSK-E40
	Tool storage capacity	40
	Max. tool diameter / length (from gauge line) / weight	Φ30 mm / 200 mm / 2 kg
Motors	Spindle motor (40% ED / cont. rating)	13.8 kW (18.5 HP) / 11.0 kW (15 HP)
Machine size	Height	2800 mm
	Floor space	3540 mm × 2970 mm
	Machine weight	15000 kg
Sounds	Equivalent continuous sound pressure level at operator position (depend on optional equipment)	Less than 80 dB (A)



## Standard and Optional Equipment

		Standard : ● Option : ○
		UD-400/5X
Machine	Work light	●
	Spindle 45000 rpm (HSK-E40)	●
	Ballscrew core cooling (X-, Y-, Z-axis)	●
Factory Automation	40 tool magazine	●
	80 tool magazine	○
	Work measurement printout (Printer not included)	○
	Scale feedback (X-, Y-, Z-axis)	●
	Scale feedback (B-, C-axis)	●
	Absolute positioning system	●
	Remote manual pulse generator (wired)	○
	Remote manual pulse generator (wireless)	○
	Auto power ON / OFF + warm-up operation	●
	Operation end buzzer	○
	Status light (3 colors)	○
	Automatic workpiece measurement (wireless touch probe RMP600)	○
	Preparation for Mazak monitoring system B (RMP600)	●
	Preparation for pneumatic fixtures 4 ports × 4 M code (both sides)	○
Safety Equipment	Operator door interlock	●
Coolant / Chip Disposal	Coolant system	●
	Work air blast	○
	Oil skimmer (RB-200)	○
	Oil mist coolant	○
	Mist collector (GP500)	○
	Coolant temperature control	○
	Hand held coolant nozzle	○
	Work washing coolant	○
	Flood coolant 30 L/min	●
	Top cover	●
Chiller unit	●	
Others	Manuals	●
	Additional manuals	○

Standard and optional equipment vary by market.

# Machine Dimensions

Unit : mm

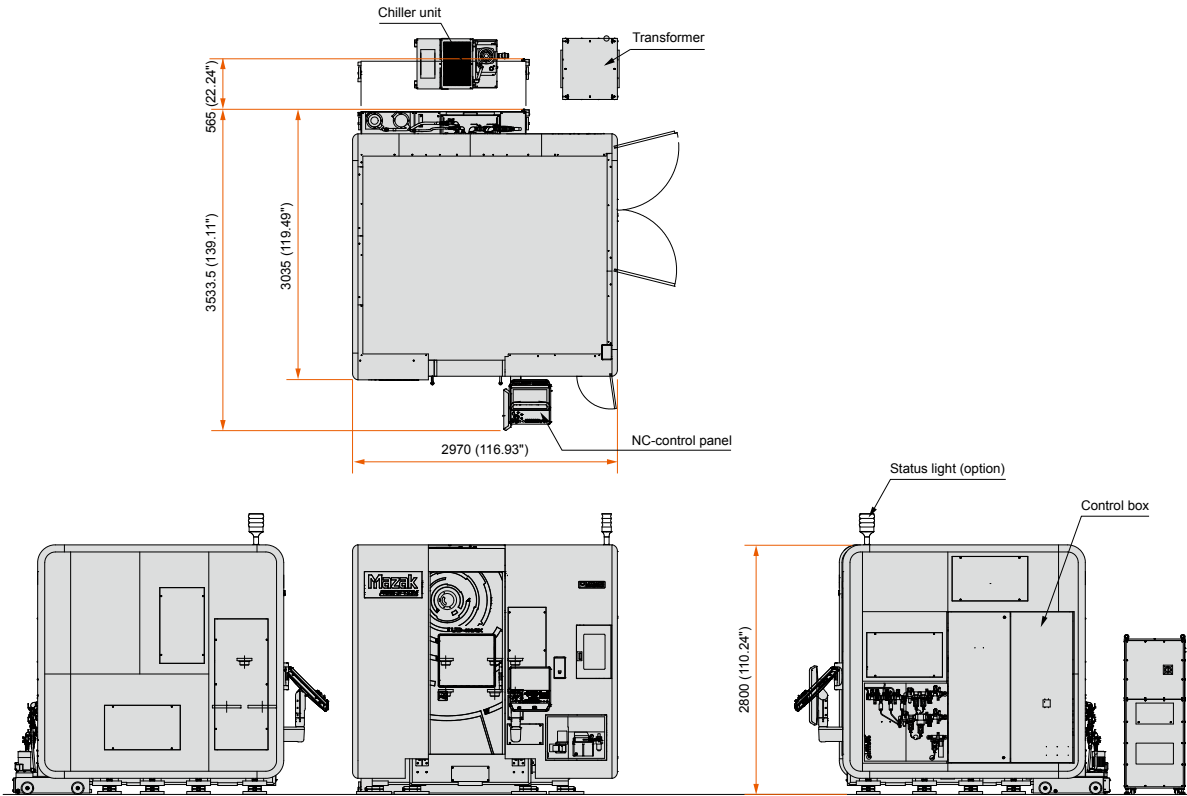

## MAZATROL SmoothX Specifications

	MAZATROL	EIA
Number of controlled axes	Simultaneous 2 ~ 4 axes	Simultaneous 5 axes
Least input increment	0.0001 mm, 0.00001 inch, 0.0001 deg	
High speed, high precision control	Shape compensation, Smooth corner control, Rapid traverse overlap, Rotational-shape correction	Shape compensation, Smooth corner control, Rapid traverse overlap, Rotational-shape correction, High-speed machining mode, High-speed smoothing control, 5-axis spline*
Interpolation	Positioning (interpolation), Positioning (non-interpolation), Linear interpolation, Circular interpolation, Cylindrical interpolation, Polar coordinate interpolation, Synchronous tapping*	Positioning (interpolation), Positioning (non-interpolation), Linear interpolation, Circular interpolation, Spiral interpolation, Helical interpolation, Cylindrical interpolation*, Involute interpolation*, Fine spline interpolation*, NURBS interpolation*, Polar coordinate interpolation*, Synchronous tapping*
Feedrate	Rapid traverse, Cutting feed, Cutting feed (per minute), Cutting feed (per revolution), Dwell (time / rotation), Rapid traverse override, Cutting feed override, G0 speed variable control, Feedrate limitation, Variable acceleration control, G0 slope constant*	Rapid traverse, Cutting feed, Cutting feed (per minute), Cutting feed (per revolution), Inverse time feed, Dwell (time / rotation), Rapid traverse override, Cutting feed override, G0 speed variable control, Feedrate limitation, Time constant changing for G1, Variable acceleration control, G0 slope constant*
Program registration	Number of programs : 256(Standard) / 960(Max.), Program memory : 2 MB, Program memory expansion : 8 MB*, Program memory expansion : 32 MB*	
Control display	Display : 19" touch panel, Resolution : SXGA	
Spindle functions	S code output, Spindle speed limitation, Spindle speed override, Spindle speed reaching detection, Constant surface speed, Spindle speed command with decimal digits, Multiple position orient, Synchronized spindle control, Max. speed control for spindle	
Tool functions	Number of tool offset : 4000, T code output for tool number, Tool life monitoring (time), Tool life monitoring (number of machined workpieces)	Number of tool offset : 4000, T code output for tool number, T code output for group number, Tool life monitoring (time), Tool life monitoring (number of machined workpieces)
Miscellaneous functions	M code output, Simultaneous output of multiple M codes	
Tool offset functions	Tool position offset, Tool length offset, Tool diameter / tool nose R offset, Tool wear offset	Tool position offset, Tool length offset, Tool diameter / tool nose R offset, Tool wear offset
Coordinate system	Machine coordinate system, Work coordinate system, Local coordinate system, Additional work coordinates (300 set)	
Machine functions	-	Rotary axis pre-filter, Angled surface cutting, Hobbing II*, Shaping function*, Dynamic compensation II*, Tool center point control*, Tool radius compensation for 5-axis machining*, Workpiece positioning error compensation*
Machine compensation	Backlash compensation, Pitch error compensation, Geometric deviation compensation, Volumetric compensation*	
Protection functions	Emergency stop, Interlock, Stroke check before travelling, Retraction function for the vertical axis, SAFETY SHIELD (manual mode), SAFETY SHIELD (automatic mode), VOICE ADVISER	
Automatic operation mode	Memory operation	Memory operation, Tape operation, MDI operation, EtherNet operation*
Automatic operation control	Optional stop, Dry run, Automatic handle control, MDI control, TPS, Restart, Machine lock	Optional block skip, Optional stop, Dry run, Automatic handle control, MDI control, TPS, Restart, Restart2, Collation stop, Machine lock
Manual measuring functions	Tool length and tip teach, Touch sensor coordinates measurement, Workpiece offset measurement, WPC coordinate measurement, Measurement on machine	Tool length and tip teach, Tool offset teach, Touch sensor coordinates measurement, Workpiece offset measurement, WPC coordinate measurement, Measurement on machine
Automatic measuring functions	WPC coordinate measurement, Automatic tool length measurement, Sensor calibration, Tool breakage detection, External tool breakage detection*	Automatic tool length measurement, Sensor calibration, Tool breakage detection, External tool breakage detection*
MDI measurement	Semi automatic tool length measurement, Full automatic tool length measurement, Coordinate measurement	
Interface	PROFIBUS-DP*, EtherNet / IP*, CC-Link*	
Card interface	SD card interface, USB	
EtherNet	10 M / 100 M / 1 Gbps	

\*Option



# Mazak

## YAMAZAKI MAZAK CORPORATION

1-131 Takeda, Oguchi-cho, Niwa-gun, Aichi-pref., Japan  
TEL : +(81)587-95-1131 FAX : +(81)587-95-2717

[www.mazak.com](http://www.mazak.com)

- Specifications are subject to change without notice.
- This product is subject to all applicable export control laws and regulations.
- The accuracy data and other data presented in this catalogue were obtained under specific conditions. They may not be duplicated under different conditions. (room temperature, workpiece materials, tool material, cutting conditions, etc.)